

# Wicketed Bagging & Sealing System

## Ideal for most free flowing product:

- Frozen Seafood
- Frozen Meat Patties
- Frozen Produce
- Frozen Baked Goods
- Frozen Pasta
- Snack Foods
- Seeds & Grain
- Pet Treats
- Fasteners



WBS 0918 WITH  
STAINLESS STEEL &  
MOBILITY KIT OPTIONS

Automatic Wicketed Bagger designed to bag and seal a wide variety of product in various sizes and types of both poly and laminated pre-made bags.

### FEATURES and BENEFITS:

- Fast, tool free, bag changeover
- Compact footprint
- Uniquely designed sealhead neatly seals, trims, and codes in one operation
- Low cost equipment alternative for filling of specialty bags, including press to close zipper, slider, and stand-up pouches
- Operator friendly touch screen control
- Communicates with most feeder devices
- Gentle product handling

2 year limited warranty on JMC parts.

Call for more information 1-800-263-5252.

[www.jmcpackaging.com](http://www.jmcpackaging.com)

At JMC Innovation Never Stops



SINCE 1961

## **NEW!** POSITIVE BAG OPENING FEATURE

(Patent Pending)

- provides for reopening of closed zippers, minimizing wastage and maximizing production

# Wicketed Bagging & Sealing System

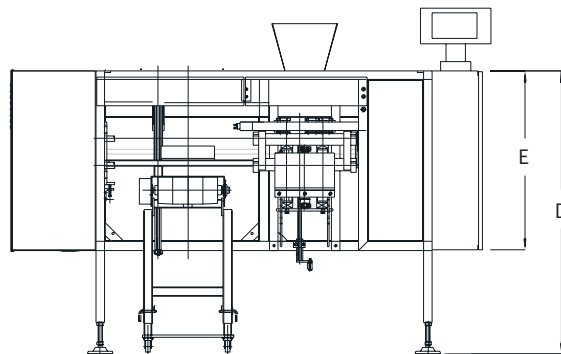
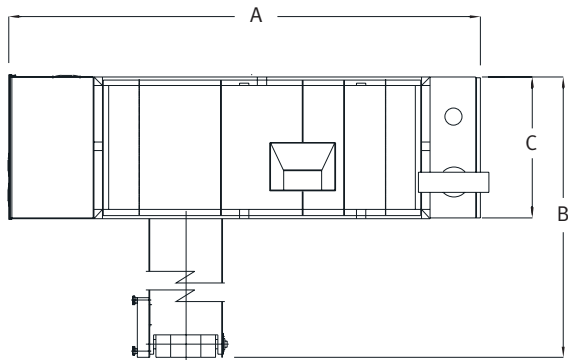

MODEL	BAG FACE SIZE RANGE:	DIM. "A"	DIM. "B"	DIM. "C"	DIM. "D" (MIN TO MAX)	DIM. "E"
WBS 0612	6" TO 12"	78 11/16"	APPROX. 90"	23 5/8"	44 3/4" TO 47 3/4"	30"
WBS 0815	8" TO 15"	78 11/16"	APPROX. 90"	23 5/8"	44 3/4" TO 47 3/4"	30"
WBS 0918	9" TO 18"	83 11/16"	APPROX. 90"	23 5/8"	54 3/4" TO 57 3/4"	30"

A fully automatic wicketed bagger, designed to open the bag, receive a charge from most types of feeding devices, seal the bag with an integral heat sealer, and then transfer the finished bag onto a discharge conveyor. Will also accept hand feeding when equipped with a foot pedal.

## STANDARD FEATURES:

- P.L.C. (programmable logic controller)
- Temperature and speed controlled seal head complete with pneumatic scrap removal and bagtop trimmer
- Stainless steel product contact surfaces
- Automatic bag discharge
- Take away conveyor with adjustable discharge height
- Adjustable infeed hopper
- Integral electrical control panel which can be interfaced to a product feeding device
- Auxiliary blower for oversized product bags (on WBS 0918 only)
- Touch Screen Control
- Low Bag Supply Warning

## OPTIONS:

- Bag Saddle (recommended for weights over 5kg./11lbs.)
- Integral embossing date/lot coder 10 digit capacity
- Dust Extraction Nozzle - ready to be hooked up to existing dust collecting system
- Spare Parts Kit
- Stainless Steel option for light washdown capability
- Mobility Kit
- Positive Bag Opening Device (patent pending) for reopening zipper bags

- Horizontal Jaws for positive presentation of side seam type, laminated pouches
- Vibratory Bag Saddle to assist in product settling
- Vibratory Infeed Chute to reduce product bridging
- Gas Flush
- Front Access Scrap Bin
- Settling Conveyors to reduce void in cartons
- Foot pedal for hand feeding

## SPECIFICATIONS:

Production capacity: up to 20 bags per minute (see your representative)

Power requirement: 115v 10amp (WBS 0612, WBS 0815)  
208Y120 (WBS 0918)

Air requirement: 3 CFM @ 80 PSI

Material capacity: LDPE films from 1 through 6 mils

Shipping weight: Approx. 985 lbs.

*Manufactured for the world market by:*

## JMC PACKAGING EQUIPMENT

3470 Mainway  
Burlington, Ontario, Canada, L7M 1A8  
Toll-free: 1-800-263-5252 If busy, call: (905) 335-4196  
FAX: (905) 335-4201  
E-Mail: [jmc@nas.net](mailto:jmc@nas.net)  
[www.jmcpackaging.com](http://www.jmcpackaging.com)

*Represented By:*

## ALLIEDFLEX Technologies, Inc

8236 Shadow Pine Way  
Sarasota, FL 34238 USA  
Phone: 941 923 1181 FAX: 941 925 4714  
E-Mail [dfc@alliedflex.com](mailto:dfc@alliedflex.com)